

RT15A RT20/25ST

The Stand-on Reach Stacker
Designed for Most
Demanding Applications



RT15A

INTRODUCTION

The RT Stand-on series Reach Truck are ideal choice for high rack application with heavy loads of capacity 1500`2500kg and max. lift height up to 8000mm. With its integrated reach forward mast and small turning radius, the bootm shelf of the rack is no longer obstacle.

It is perfect solution for large warehouse with narrow aisle racks for efficeinet storage and handling of goods.

ADVANTAGES

■ Regenerative braking

If brake when driving the motor automatically power off to maximize reduce power consumption and extend battery working time: The use of regenerative braking technology minimize the wear of braking efficiently, to ensure the brake safety and efficiency of energy recovery.

■ Advanced configuration

The truck is equipped with AC system and electric power steering, with leading brands from the industry such as German Schabmueller drive and steer motor, ZF gear box, German mast profile, Ameircan KDS lift motor, American Curtis controller, and DIN standard big capacity battery of 480Ah.

■ Hydraulic system

International advanced connectors, hoses and abrasion resistance, high temperature resistance, high flexible import seals reasonable layout of hard and soft tube to ensure that the whole hydraulic system cooling, sealing, durability, safety and efficiency.

RT20/25ST



Reach Truck/Tow Tractor

■ Comfortable and beautiful design

Modern design of control pedal, and the damping pedal with ergonomic design ensures comfortable driving.

■ Mast system

The mast has the reach forward function which allows the truck to store the goods without moving of the truck itself which is convenient and safe; High quality imported H-shape mast ensures that the vehicle load capacity.

■ Emergency button

Safe and convenient configuration of the emergency button, emergency one-time cut off all energy, which greatly increase safety.

■ Safety

The mast piping system with safe speed limit valve, effectively control the rate of lowering of goods. High standards of craftsmanship, aterials and quality ensures better performance in harsh conditions

■ Buffer system for fork lowering and mast forward/backward

Buffer system for fork lowering and mast forward backward increase vehicle safety and operating comfort.



■ Electronic control functions

The electrical energy, timing, fault displays easy for operator to understand the vehicle condition and to have maintenance. the surface of electrical components is water and dust proof, the design of fully enclosed thermal of the central control unit to make the circuit more simple and reliable.

Mast table (VDI 2198)

Designation	Lowered mast height h_1 (mm)	Free lift height h_2 (mm)	Lift height h_3 (mm)	Extended mast height h_4 (mm)
RT20-25ST				
Two-stage mast	1830	140	2500	3415
	1930	140	2700	3615
	2080	140	3000	3915
	2230	140	3300	4215
	2380	140	3600	4515
	2580	140	4000	4915
	2830	140	4500	5415
Two-stage mast FFL (Full-Free-Lift)	2167	1254	4500	5415
	2335	1420	5000	5915
	2435	1520	5300	6215
	2502	1585	5500	6415
	2602	1685	5800	6715
	2667	1755	6000	6915
	2835	1920	6500	7415
	2992	2095	7000	7915
	3167	2255	7500	8415
	3335	2420	8000	8915

Mast table (VDI 2198)

Designation	Lowered mast height h_1 (mm)	Free lift height h_2 (mm)	Lift height h_3 (mm)	Extended mast height h_4 (mm)
RT15A				
Two-stage mast	1830	135	2500	3365
	1930	135	2700	3565
	2080	135	3000	3865
	2230	135	3300	4165
	2380	135	3600	4465
	2580	135	4000	4865
	2830	135	4500	5365
Two-stage mast FFL (Full-Free-Lift)	2172	1490	4500	5365
	2340	1655	5000	5865
	2440	1755	5300	6165
	2507	1820	5500	6365
	2607	1920	5800	6665
	2672	1990	6000	6865
	2840	2155	6500	7365
	3007	2320	7000	7865
	3172	2490	7500	8365
	3340	2655	8000	8865

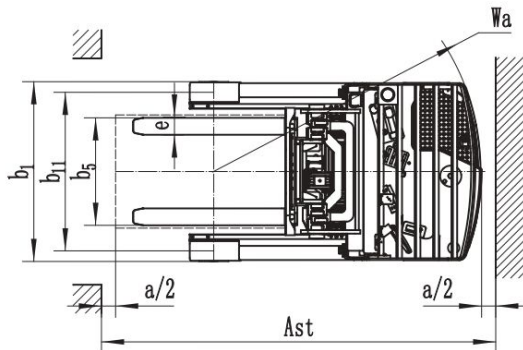
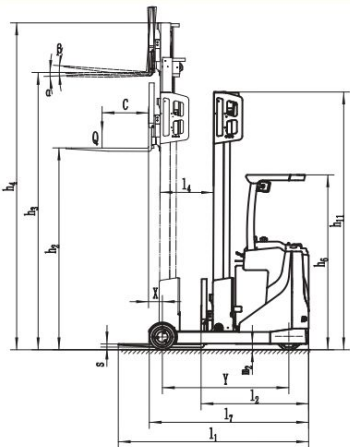

Type sheet for industrial truck acc. to VDI 2198

1KG=2.2LB 1INCH=25.4MM

			RT15A	RT20ST	RT25ST		
Distinguishing mark	1.2	Manufacturer's type designation	RT15A	RT20ST	RT25ST		
	1.3	Drive(battery,diesel,petrol,gas>manual)	Battery		Battery		
	1.4	Operator type	Stand on		Stand on		
	1.5	Load capacity / rated load	Q (t)	1.5	2.0	2.5	
	1.6	Load center distance	c (mm)	500		500	
	1.8	Load distance ,centre of drive axle to fork	x (mm)	308		208	
	1.9	Wheelbase	y (mm)	1482	1500	1636	
	Weight	2.1	Service weight	kg	3630	3550	3650
Tyres, chassis	3.1	Tires		Polyurethane	Polyurethane		
	3.2	Tire size, front	Øxw (mm)	Ø 343X140	Ø 343X140		
	3.3	Tire size, rear	Øxw (mm)	Ø 267X106	Ø 330X100		
	3.5	Wheels, number front/ rear(x=driven wheels)		2/1x+2	2/1x		
	3.7	Tread, rear	b _r (mm)	1010 / 660	1155	1155	
	Dimensions	4.1	Mast/fork carriage tilt forward/backward	α/β (°)	2/4	2/4	
		4.2	Lowered mast height	h ₁ (mm)	3340	2335	
4.3		Free lift	h ₂ (mm)	2655	1420		
4.4		Lift height	h ₃ (mm)	8000	5000		
4.5		Extended mast height	h ₄ (mm)	8865	5915		
4.7		Overhead load guardheight	h ₆ (mm)	2330	2260		
4.19		Overall length	l ₁ (mm)	2246	2380	2450	
4.20		Length to face of forks	l ₂ (mm)	1326	1310	1380	
4.21		Overall width	b ₁ (mm)	1130		1260	
4.22		Fork dimensions	s/e/l (mm)	35 / 100 / 920		40 / 120 / 1070	
4.25		Fork carriage width	b ₂ (mm)	200/760		240/760	
4.28		Reath distance	l ₃ (mm)	560	645	710	
4.31		Ground clearance ,laden,under mast	m ₂ (mm)	80		75	
4.34		Aisle width for pallets 800x1200 lengthwise	Ast(mm)	2695	2800	2870	
4.35	Turning radius	Wa (mm)	1750	1750	1880		
4.37	Length across wheel arms	l ₄ (mm)	1855	1920	2050		
Performance data	5.1	Travel speed,laden/unladen	km/h	9.5 / 9.5	10.5 / 10.5		
	5.2	Lift speed,laden/unladen	m/s	0.28 / 0.32	0.27 / 0.38		
	5.3	lowering speed,laden/unladen	m/s	0.35 / 0.31	0.45 / 0.40		
	5.4	Reath speedm,laden/unladen	m/s	0.09 / 0.12	0.10 / 0.10		
	5.8	Max.gradient performance,laden/unladen	%	10 / 15	10 / 15		
	5.10	Service brake		Electromagnetic	Electromagnetic		
Electric- engine	6.1	Drive motor rating S2 60 min	kW	5.5	6.4		
	6.2	Lift motor rating at S3 10%	kW	8.6	12.5		
	6.3	Battery acc.to DIN43531/35/36 A,B,C,no		A, 4PzS	A, 4PzS		
	6.4	Battery voltage,nominal capacity	V/Ah	48 / 360	48 / 420 / 480	48 / 480	
	6.5	Battery weight	kg	600		939	
Additional data	8.1	Type of drive control		AC-Speed Control	AC-Speed Control		
	8.2	Operating pressure for attachments	bar	110	150	170	
	8.3	Oil volume for attachments	l/min	40		35	
	8.4	Sound level at driver's ear according to EN 12053	dB(A)	<70		<70	