

SPS Semi Auto Stackers

รถยกพาเลท ยกสูง แบบกึ่งอัตโนมัติ

Cost-effective option for carrying out diverse stacking operations (loading capacity from 1000kg to 2000kg, optional lift height of 1600mm, 3000mm and 3500mm) and the loading and unloading of goods vehicles.



Precise raising and lowering via hand lever. Battery cutoff switch prevents unauthorized use. Easily cuts power to promote energy saving. Battery gauge and sealed charging dock as standard.



Additional protection for the operator through foot protection for the steering rollers. Safe parking in any situation with mechanical parking brake.

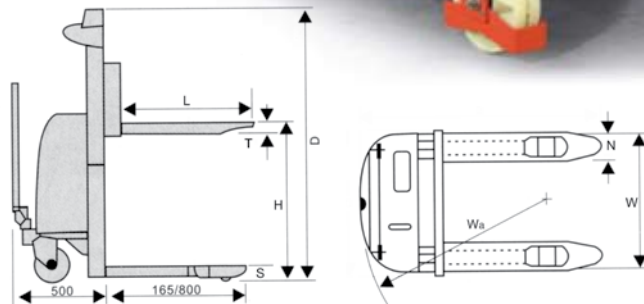

- Rigid and strong mast structure.
- Precision manufactured leak-proof, self-sealed hydraulic system.
- Rear wheel chain steering linkage and ball bearing fitted wheels ensure minimum effort needed to pilot even a fully loaded stacker.
- Built-in hydraulic power pack.
- Conforms to EN1757-1.
- Hard chrome plated piston.
- Integrated 150 AH maintenance free battery supplies strong power to effect frequent lifting tasks, an integrated charger facilitates easy and reliable charging of the integrated battery

Model รุ่น		SPS1016	SPS1030	SPS1535	SPS2016
Capacity น้ำหนักบรรทุก	kg	1000	1000	1500	2000
Min. Fork Height (S) ความสูงของเสา	mm	85	85	85	85
Max. Fork Height (H) ความสูงสูงสุดยก	mm	1600	3000	3500	1600
Min. Mast Height (D) ความสูงขั้นต่ำมาส์ท	mm	1980	2080	2020	1980
Fork Size (N x T) ขนาดงา	mm	160 x 60	160 x 60	160 x 160	160 x 60
Fork Length (L) ความยาวงา	mm	900/1100	900/1100	900/1100	900/1100
Overall Fork Width (adjust/fix) (W) ความกว้างทั้งหมดงา(ปรับแต่ง/ยึดติด)	mm	340-650		560	334-650
Radius of Gyration (Wa) วงเลี้ยว	mm	1240	1240	2100	1360
Overall Dimensions (W*L*H) ขนาดทั้งหมด	mm	800 x 1600 x 2080		1000 x 1800 x 2150	800 x 1600 x 2080
Load Wheel ล้อบรรทุกน้ำหนัก	mm	Ø 74 x 70		Ø 74 x 70	Ø 74 x 70
Steering Wheel ขนาดล้อบังคับเลี้ยว	mm	Ø 180 x 50		Ø 180 x 50	Ø 180 x 50
Battery V/Ah (5h autonomy) แบตเตอรี่		12 / 150		12 / 120	12 / 150
Lifting Motor Power กำลังยกตัวมอเตอร์	kw	1.8	1.8	2.0	1.8
Net Weight น้ำหนักสุทธิ	kg	396	466	430	500