

### Specifications

Model	TZ-50	
Measurements	Metric	US
Working height*	17.09 m	55 ft 6 in
Platform height	15.09 m	49 ft 6 in
Entry height	0.51 m	1 ft 8 in
Horizontal reach	8.89 m	29 ft 2 in
Clear outreach	7.04 m	23 ft 1 in
Up and over clearance	6.71 m	22 ft
▲ Platform length	0.68 m	2 ft 2.8 in
▲ Platform width	1.12 m	3 ft 8 in
▲ Height - stowed	2 m	6 ft 10 in
▲ Length - stowed	7.16 m	23 ft 6 in
▲ Width - stowed	1.68 m	5 ft 6 in
▲ Ground clearance - center	0.25 m	10 in
▲ Length - outrigger footprint	4.37 m	14 ft 4 in
▲ Width - outrigger footprint	4.37 m	14 ft 4 in

### Productivity

Lift capacity - standard	200 kg	440 lbs
Lift capacity - rotating platform	200 kg	440 lbs
Jib boom	1.25 m	4 ft 1 in
Jib working range	135°	135°
Self leveling platform	2.5° standard	
Platform rotation option	160° hydraulic	
AC power to platform	standard	
Turntable rotation	359° non-continuous	
Outrigger leveling capability	10°	
Drive speed	1.37 km/h	0.85 mph
Gradeability**	20%	
Towing speed rate	97 km/h	60 mph
Tongue weight - CE***	100 kg	220 lbs
Surge and parking brakes	standard	
Controls	variable speed system	
Tyre size	215 R14C	
Coupler	5.08 cm (2 in) hitch coupler standard	

### Power

Power source - standard	24V DC (four 6V 225 Ah batteries)
Power source - drive option	24V DC (four 6V 244 Ah batteries)
Power source - option	Hybrid DC/Gas Honda 4.1 kW (5.5 hp)
Fuel tank capacity	3.6 L / 0.95 gal
Hydraulic tank capacity	18 L / 4.75 gal
Hydraulic system capacity	30 L / 8.0 gal

### Sound & Vibration Levels

Sound pressure level (ground workstation)	<70 dBA	<70 dBA
Sound pressure level (platform workstation)	<70 dBA	<70 dBA
Vibration	<2.5 m/s <sup>2</sup>	<8 ft 2 in/s <sup>2</sup>

### Weight\*\*\*

Weight CE	2,025 kg	4,464 lbs
Unit weight modifiers for main options		
Platform rotation:	add 10 kg	add 23 lbs
Drive option:	add 105 kg	add 231 lbs
Bicycle guard:	add 15 kg	add 32 lbs
Full size spare tyre:	add 27 kg	add 60 lbs
Hybrid engine:	add 45 kg	add 100 lbs

### Standards Compliance

EU Directives: 2006/42/EC - Machinery (harmonized standard EN280:2013); 2004/108/EC (EMC); 2006/95/EC (LVD); 2000/14/EC (Outdoor Noise)

### Range Of Motion TZ-50

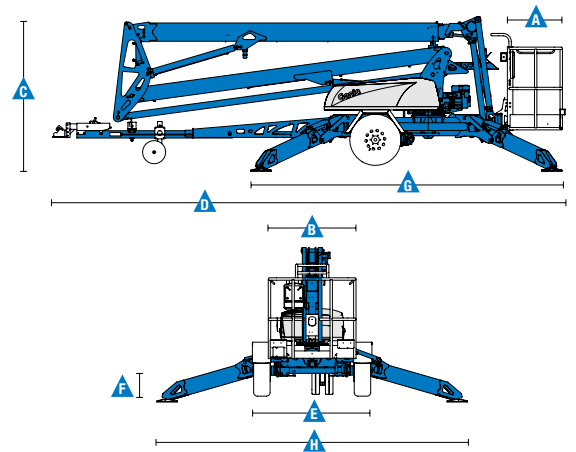
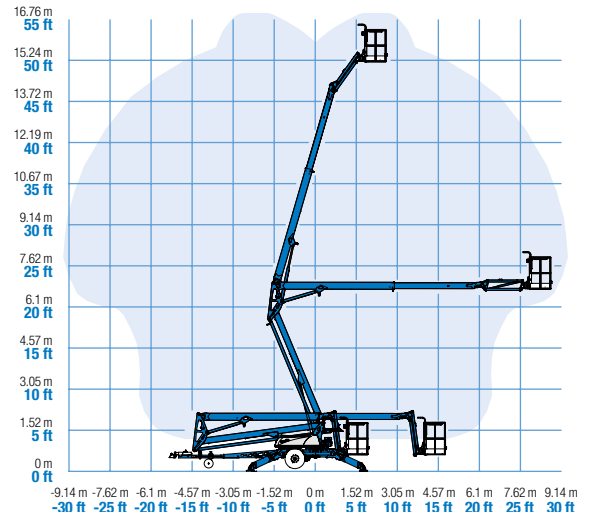

\* The metric equivalent of working height adds 2 m to platform height. U.S. adds 6 ft to platform height.

\*\* Gradeability applies to driving on slopes. See operator's manual for details regarding slope ratings.

\*\*\* Weight will vary depending on options and/or country standards.

### Features

Standard Features	Easily Configured To Meet Your Needs	Options & Accessories
-------------------	--------------------------------------	-----------------------

#### Measurements

- 17.09 m (55 ft 6 in) working height
- 29 ft 2 in (8.89 m) horizontal reach
- Up to 227 kg (500 lbs ) lift capacity

#### Productivity

- Industry leading working envelope
- Extension boom
- Self-levelling platform
- 1.25 m (4 ft) jib with 135° working range
- AC wiring to platform
- Hydraulic outriggers
- Automatic 10° levelling system
- Outrigger interlocks
- Mechanical parking brake
- Hydraulic surge brakes
- Auxiliary pump down
- 5.08 cm (2 in) ball coupler
- Combination hitch with coupler lever lock
- Dual jockey wheels
- 359° non-continuous turntable rotation
- Easy to access batteries
- Hour meter
- Tilt alarm / sensor
- Forklift pockets
- Illuminated outrigger indicators
- Wheel chocks
- Spare tyre
- Battery charge indicator (BCI)
- Ladder
- Certified load sensor

#### Power

- 24V DC power source (four 6V 225 Ah batteries)

#### Platform Options

- Aluminum 0.68 x 1.12 m (26.8 x 44 in)
- 160° hydraulic platform rotation <sup>(1)</sup>

#### Power Options

- 24V DC power source
- Hybrid Honda 4.1 Kw (5.5 Hp) 45 amp charging system

#### Drive

- Drive option

#### Coupler

- 5.08 cm (2 in) ball coupler

#### Tyres

- 215 R14C tyres

#### Productivity

- Power to platform (incl. plug, socket and ground fault interrupt leakage on request)
- Track & Trace <sup>(2)</sup> (GPS unit providing machine location & operating information)
- Low temperature cut-out module
- Drive option with high capacity 244 Ah batteries pack
- Non-marking outrigger footpads
- Bicycle guard <sup>(3)</sup>
- Horn
- Flashing Beacon
- Fluorescent tube caddy
- Tool tray

#### Power

- Hybrid Honda 4.1 Kw (5.5 Hp) 45 amp charging system option



<sup>(1)</sup> Factory-fit option only

<sup>(2)</sup> Includes a first 2 years subscription

<sup>(3)</sup> Mandatory for France, Denmark, Netherlands

### Germany

Kostenlose Tel: 0800 1809017 (innerhalb Deutschland Durchwahl 2) Tel: +49 4221 491 810 Fax: +49 4221 491 820 Email: AWP-InfoEurope@terex.com  
Informationen über unsere Standorte weltweit finden Sie unter <http://www.genielift.de/standorte>

### Fertigung und Vertrieb weltweit

Australien · Brasilien · Karibik · Zentralamerika · China · Frankreich · Deutschland · Italien · Japan · Korea · Mexiko · Russland · Südostasien · Spanien · Schweden · Vereinigte Arabische Emirate · Vereinigtes Königreich · USA

Technische Daten und Preise können ohne vorherige Ankündigung oder Verbindlichkeit geändert werden. Fotos und/oder Zeichnungen in diesem Dokument dienen ausschließlich Illustrationszwecken. Informationen über den korrekten Einsatzzweck entnehmen Sie bitte dem jeweiligen Bedienerhandbuch für das entsprechende Produkt. Zuwiderhandlungen entgegen den Anweisungen des entsprechenden Bedienerhandbuchs oder unverantwortliches Handeln können schwere oder tödliche Verletzungen zur Folge haben. Die ausschließlich für unsere Produkte anzuwendende Gewährleistung ist die Standardgewährleistung, die sich auf das entsprechende Produkt und den Verkauf bezieht. Wir gewähren keine anders vereinbarte oder stillschweigend implizierte Gewährleistung. Aufgeführte Produkte und Serviceleistungen können Handelsmarken, Servicenamen oder Markennamen der Terex Corporation und/oder ihrer Tochterunternehmen in den U.S.A. oder in anderen Ländern darstellen. Genie ist ein eingetragenes Warenzeichen von Terex South Dakota, Inc. © 2015 Terex Corporation.

